

Magnetic Loop Antenna's.

Why is an Magnetic Loop antenna so special, this antenna is picking only the MAGNETIC part of the ELEKTRO MAGNETIC radio wave. The big advantage of this antenna is that the electric interference from the big city (streetlights, television's , cars etc...) have no influence on the received signal. With the loop you can hear other stations that you can't hear if you use a DIPOLE, with a dipole the stations are buried in the noise.

Multi Turn Magnetic Loop.

This is the first loop I build from a article in the QST from February 1996, it's 30 Inch-diameter, and it's designed by G2BZQ/WØ for 80 M.

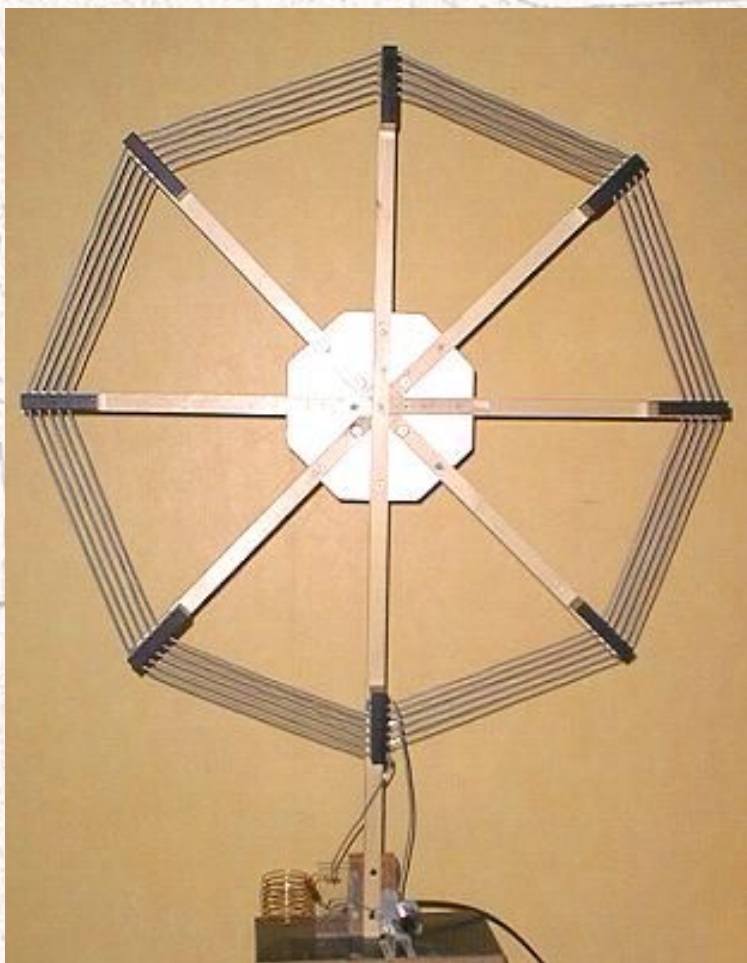

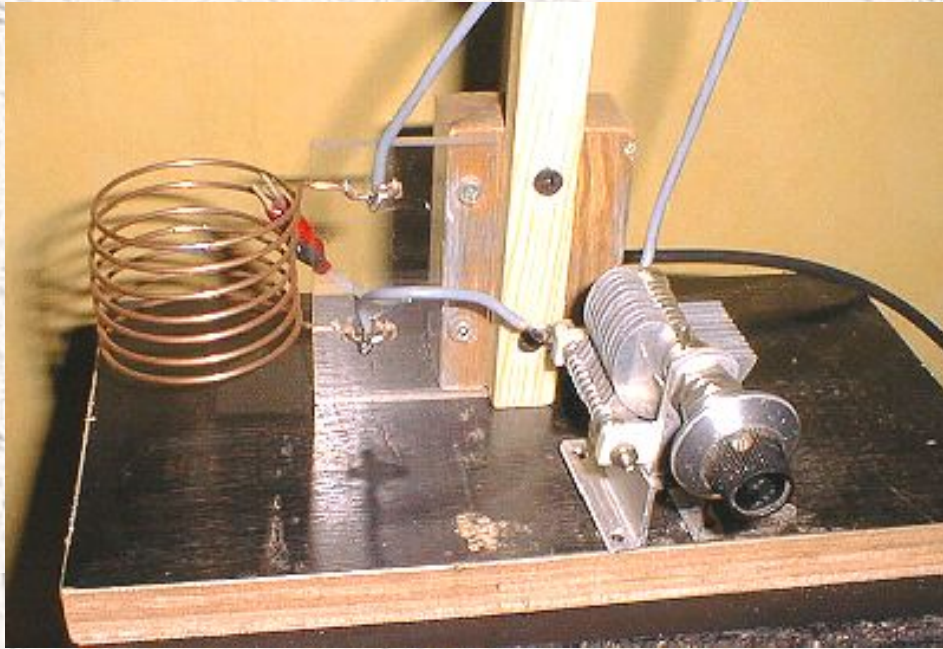

Single Turn Magnetic loops



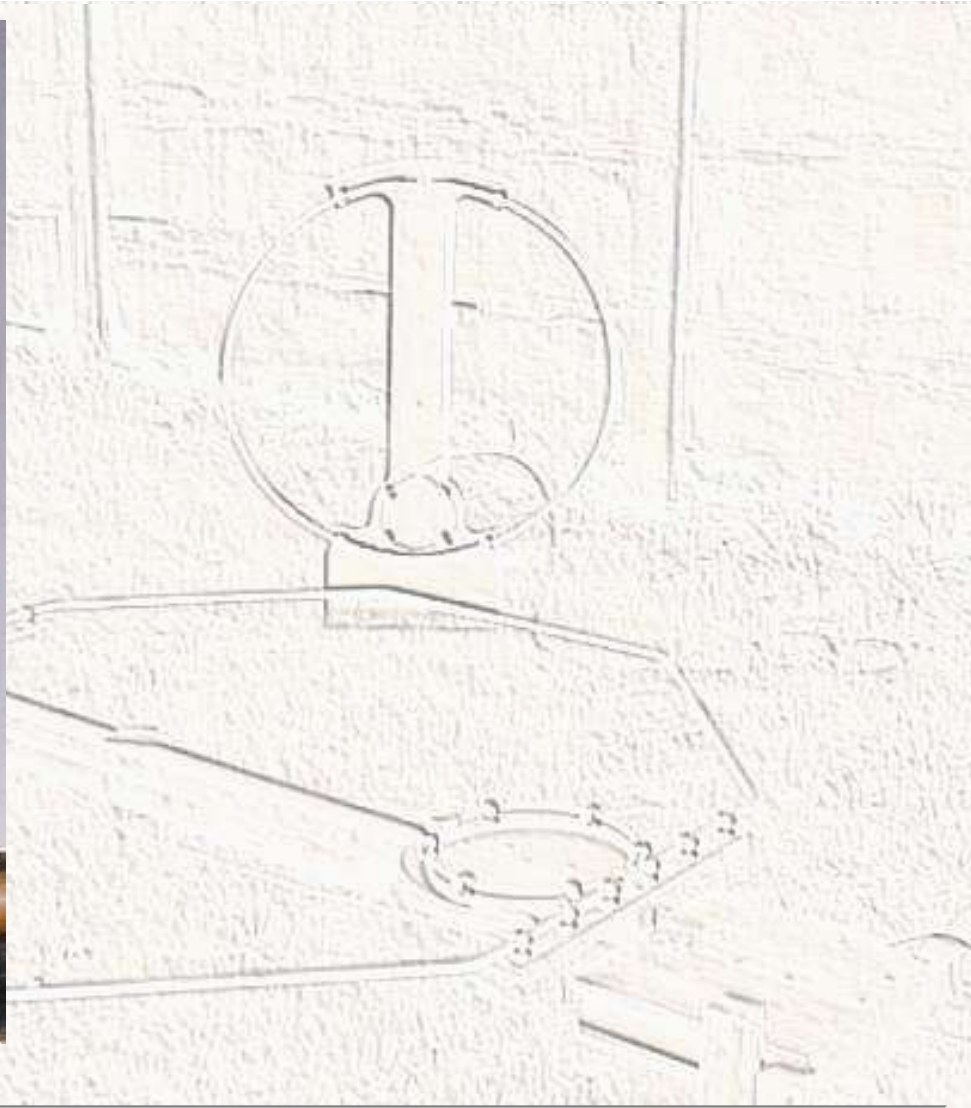
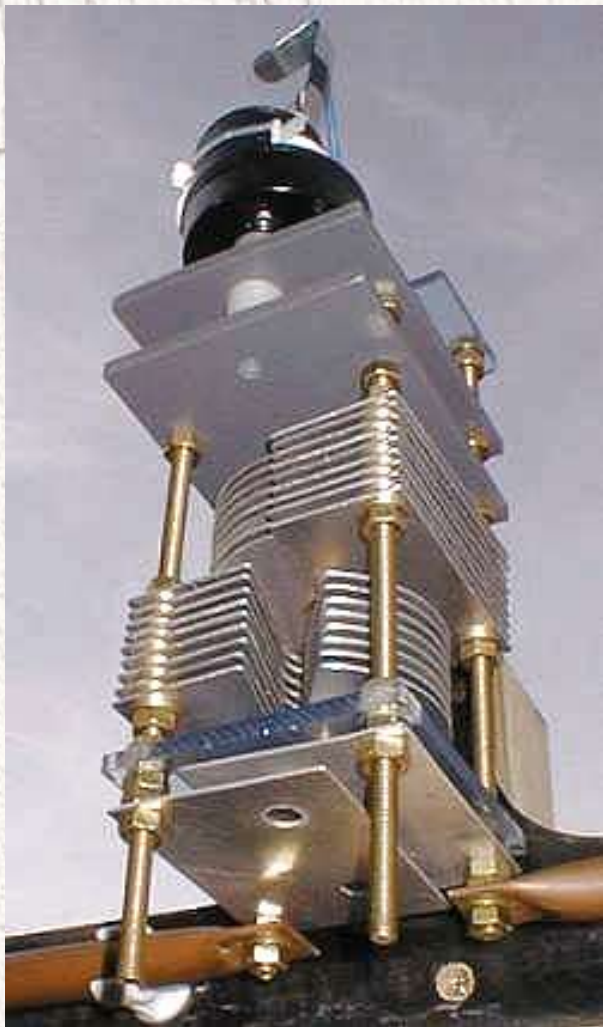

The first one turn loop that I built was made from 75 Ohm TV Coax and with a small explanation in the RSGB handbook for radio amateurs. I used the outer screen from the coax and the results of the loop where good. The next loop I built is a octagon loop in 15mm copper tube with a circumference of 4.8 meter (16 feet).

The frequency range of this loop goes from 14 MHz to 7 MHz and works fine. The biggest problem is the tuning capacitor, if you transmit with a power of 100 W you need a capacitor with a voltage rating of 5000 Volt. A capacitor which can handle this voltage is hard to find over here and if you find one they are very expensive.

The first capacitor I built was a design from GW3JPT from a article in the RADIO COMMUNICATION from February 1994. It is a split stator capacitor with a capacitance of 140 pF and with a voltage rating of 6000 Volt.

The capacitor is remote tuned with the use of a small BBQ spit motor.



The second capacitor I built is my own design and it's a butterfly capacitor because the losses are lower than a split stator. The capacitance is 5-65 pF and the voltage rating is 7200 volts. I used it for the small loop with a dia. of 800 mm (2.66 feet) and the frequency range of this loop is from 28 MHz to 14 MHz. The Aluminum plates of 1 mm for the capacitors are cut with a JIG SAW.

Most asked Questions:

I`d like to talk a little more on your setup. it seems like something which I could get together if only some more data was available. do you have any notes etc still laying about since its build ?

The theory for calculating the loop is very simple. The circumference of a magnetic loop is 1/4 wave of the design frequency.

Example for 14 MHz.

$$300 / 14 \text{ MHz} = 21.428 \text{ m is 1 wave}$$

$$21.428 / 4 = 5.357 \text{ m is 1/4 wave circumference}$$

$$5.357 / 3.14 = 1.706 \text{ m diameter.}$$

The recommendations are that you can tune the loop from the design frequency to the frequency divided by 2 to keep the efficiency acceptable.

14 MHz / 2 = 7 MHz

I made the small loop (800mm / 31.5 ") from soft copper tube on a role that you can buy in a plumbershop and it's easy to make a nice circle if you draw on the ground a circle with a rope and a piece of chalk.

For mounting the loop to the hardboard I used plastic clamps that they use for mounting copper tube on the wall.

why is a butterfly capacitor better?

For high voltages and currents the use of Capacitors with wiper contacts is not recommended. That's why they use capacitors in serie's. The pro for serie's capacitors is that the voltage rating is doubled. The anti is that the value of capacitance is divided by 2.

For the split stator capacitor the 2 capacitors are connected in series by the shaft (bleu) and the red spots on the first drawing are losses.

For the butterfly capacitor the 2 capacitors are directly connected in series by the rotors and gives less losses.

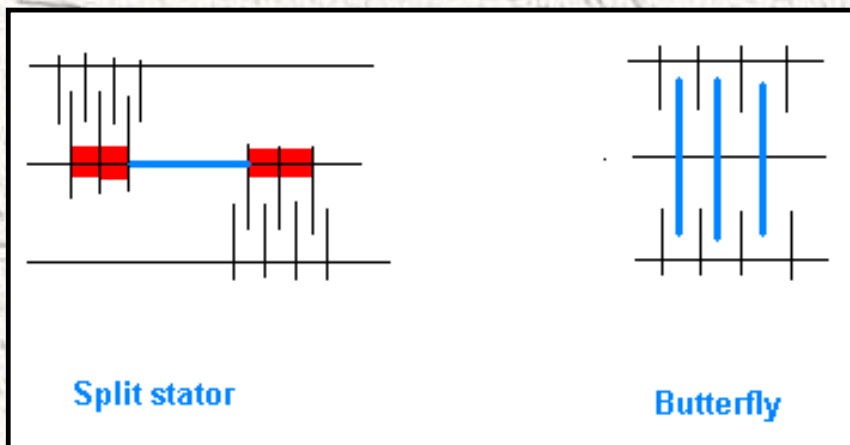

Do you know of anyone that has built a similar loop that outperformed a garden variety dipole?

Compare antenna's is very difficult , sometimes I have for 60 % better signals in RX and TX on the loops then on the dipole.

In Theorie is the performance of a magnetic loop - 0.4 dB lower then a dipole or a vertical .

I have over here a homebrew trap dipole from 40-20-15-10m and the height aboveground is only 7 m(23 ft), for a good performance on 40 m the dipole must have a height of 1/2 wave above ground (66ft). I don't have a radiation angle on 40 m and it's only good for contacts in Europe and not good for DX, now the 1.5 m loop tuned to 7 MHz with a efficiency of 38 % (38 w ERP) and a angle radiation of about 20 degrees performs better than the dipole because the vertical magnetic loop only 1 M above ground as a angle radiation and the dipole don't.

Another advantage is that the reception on a loop is much better, on 20m I have with the dipole S5 noise from the big city, if I switch to the loop I have S1 noise and hear stations who are buried in the noise when I use a dipole.

Coupling loop dimensions?

I find that the best way to feed the loop is with the shielded 1/5 Faraday loop made from coax RG213 or RG8, I tried the gamma match but I had problems to keep the VSWR low on all Bands, the shielded loop gives on all bands VSWR 1.1 and reduce more noise pick-up then the gamma match.

I found out that if you use a 1/5 Faraday loop, that the loop is too big, making the loop smaller with 0.5 inch by the time in circumference and checking with a field strength meter you can see that the radiated power increase.

The place of the feeding loop is placed at the electrically neutral point on the loop and that is 180° from the capacitor and I have the best results with the feeding loop close to the ground and the capacitor far from the ground.

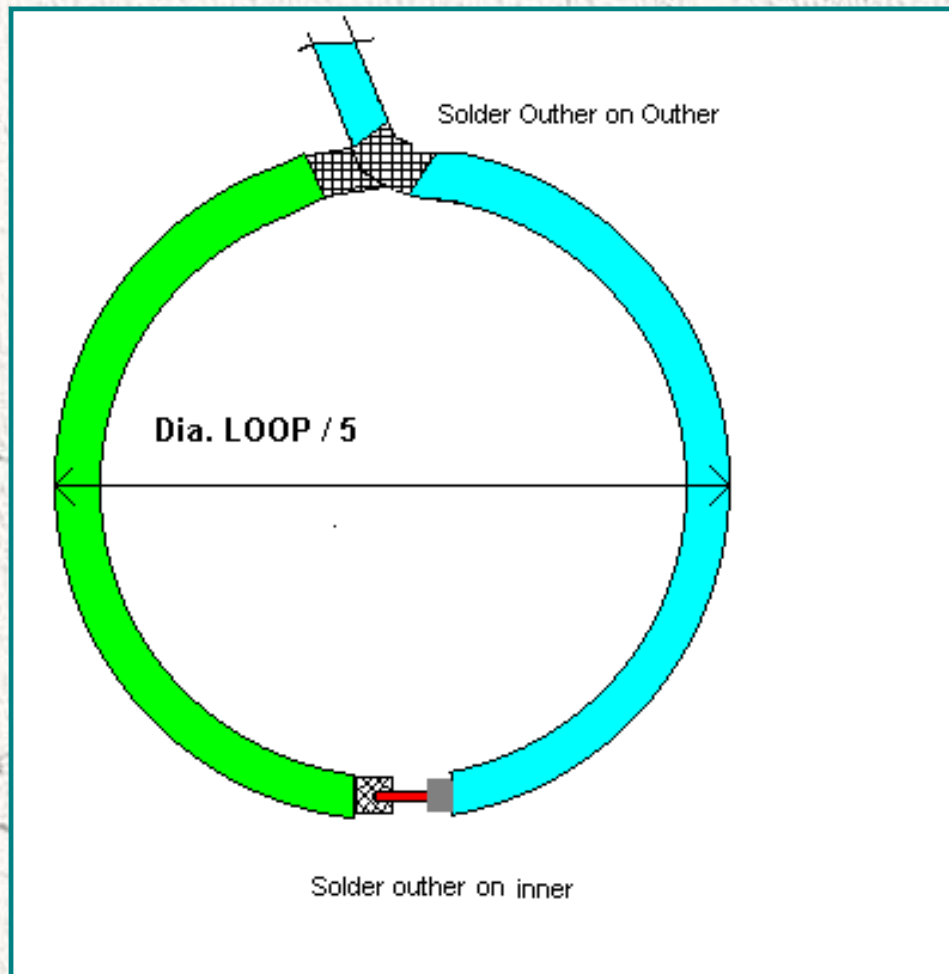

I was wondering if you worried about the resistance of the mechanical joints (copper pipe bolted to the capacitor) significantly reducing your radiation efficiency as I think the radiation of these antennas can get as low as .01 ohms

Solder or weld the capacitor plates is always the best, but I'm afraid if you make the spacers and the plates in ALU that with welding everything is gonna bend from the heat and I know from practice (I work in a maintenance

workshop) that welding ALU is coarse. Another possibility is using all brass or copper and solder, there are hams that using double PC board for the plates.

I made a QSO in phone with Florida, RPRT 5-5 and the other station used a vertical antenna, with the small loop (800mm and theoretical effieency 41 % on 14 Mc) vertical in the garden and the states side is through the house. I was very happy with the results , so I think that a capacitor maded with torqued compressed joints is good enough for using 100 W.

Have the dissimilar metal joints weather well?

To keep the oxidation low on the dissimilar metals I used a thin coat of vaseline after assemble the capacitor and with the tupper ware a like plastic box it is good protect against all wheather conditions.

How to find the radiation angle of the antenna?

Can it be found practically?

Finding the radiaton of a magnetic loop is very easy, with a TL-lichtgt tube you can see it, with abt 10 w power on the the loop with the TL-tube in the plain of the loop at right angle to the circle you see the tube lightning, there where the the light is the farest on the tube thats the radiation angle.

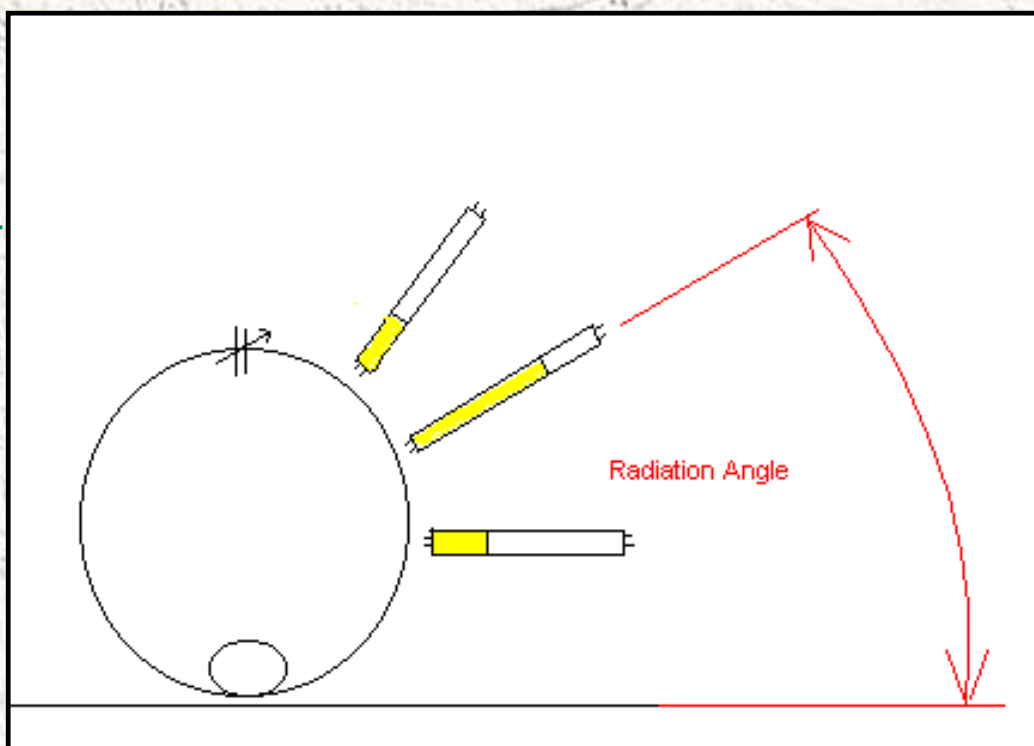

When you refer to washers, nuts and rods you use the term "M6".Please forgive my ignorance, but to what does "M6" refer? Does this mean 6mm?

M6 is (M=metrical) and 6 is indeed 6 mm threaded rod and

you can compare the size with W1/4" (6.35mm) .

A very easy to build Piston Capacitor.

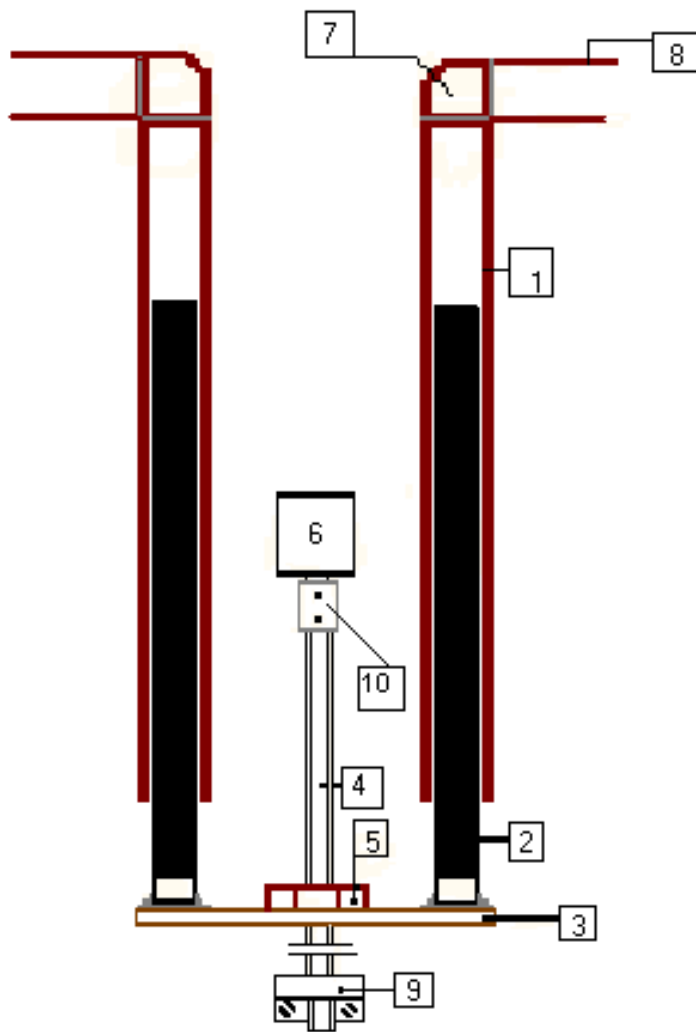

- 1) Copper tube
- 2) Coax RG8 or 213
- 3) Double PCB
- 4) Threaded Rod 1/4"
- 5) Brass nut
- 6) Motor with reduktion or stepper motor
- 7) Copper Elbow 90°
- 8) Loop
- 9) Bushing from old var resitor
- 10) Couple shaft (PVC)

How to build your own Butterfly Capacitor.

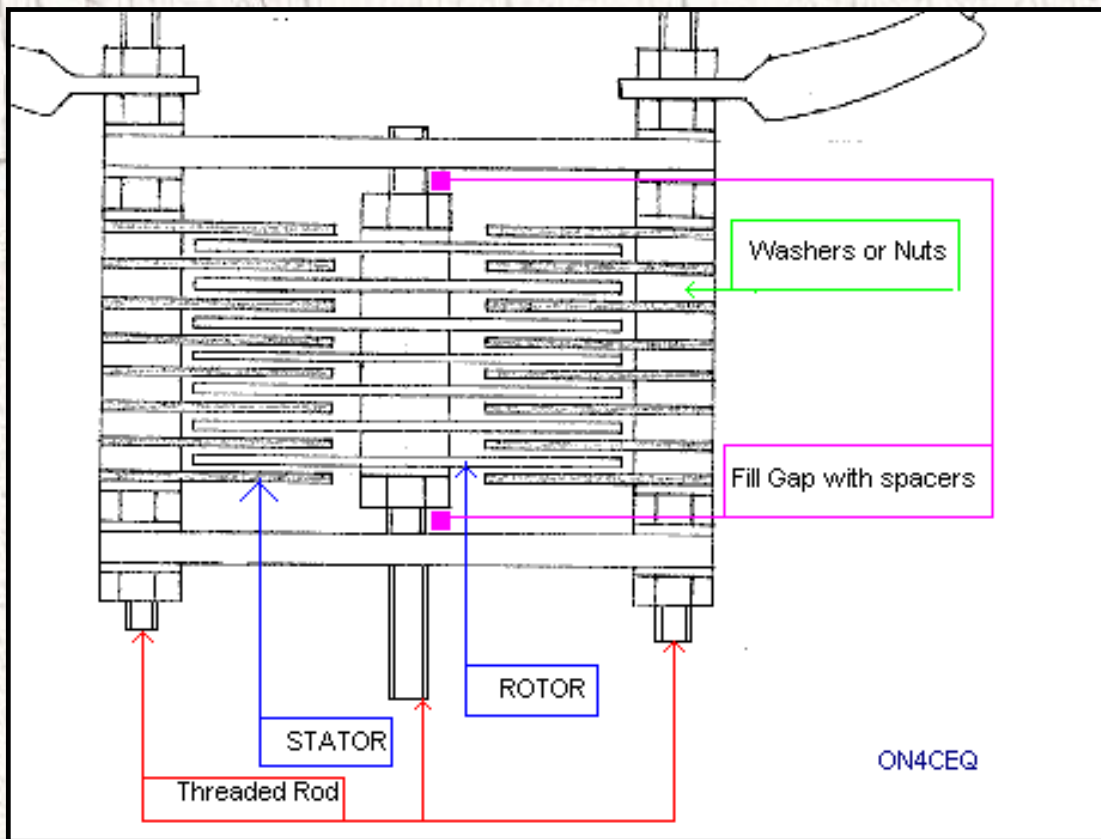

The best material for the front and the back is CLEAR PVC 3 or 5 mm thick as alternative you can use GREY PVC or 2 sheets pboard together with the copper removed .

The best material for the washers, nuts (M6) and threaded rod (M6) is brass or stainless steel,(NON MAGNETIC MATERIALS for the losses).

For the spacing of the vanes you can use 2 washers M6= (6Kv) or a nut M6 = (12 Kv) if you use aluminum plate 1 mm thick.

If you use a nut then the best thing to do is remove the thread by drilling with \varnothing 6.2 mm.

The effective area for the vanes is 11.7 cm² and with the formula

for 2 washers = $(0.0885 \times 11.7 \text{ cm}^2) / 0.1 \text{ cm} = 10.35 \text{ pF}$ for 1 air gap.

for 1 nut = $(0.0885 \times 11.7 \text{ cm}^2) / 0.2 \text{ cm} = 5.17 \text{ pF}$ for 1 air gap

Example:

If you you make a capacitor with 2 washers as spacing and you make 5 rotor vanes and 6 stator vanes then you have 10 air gaps.

$10.35 \text{ pF} \times 10 = 103 \text{ pF} + 10 \text{ pF}$ stray capacitance = $113 \text{ pF} / 2 = 56 \text{ pF}$

The final result is a capacitor with a value from 5 - 56 pF.

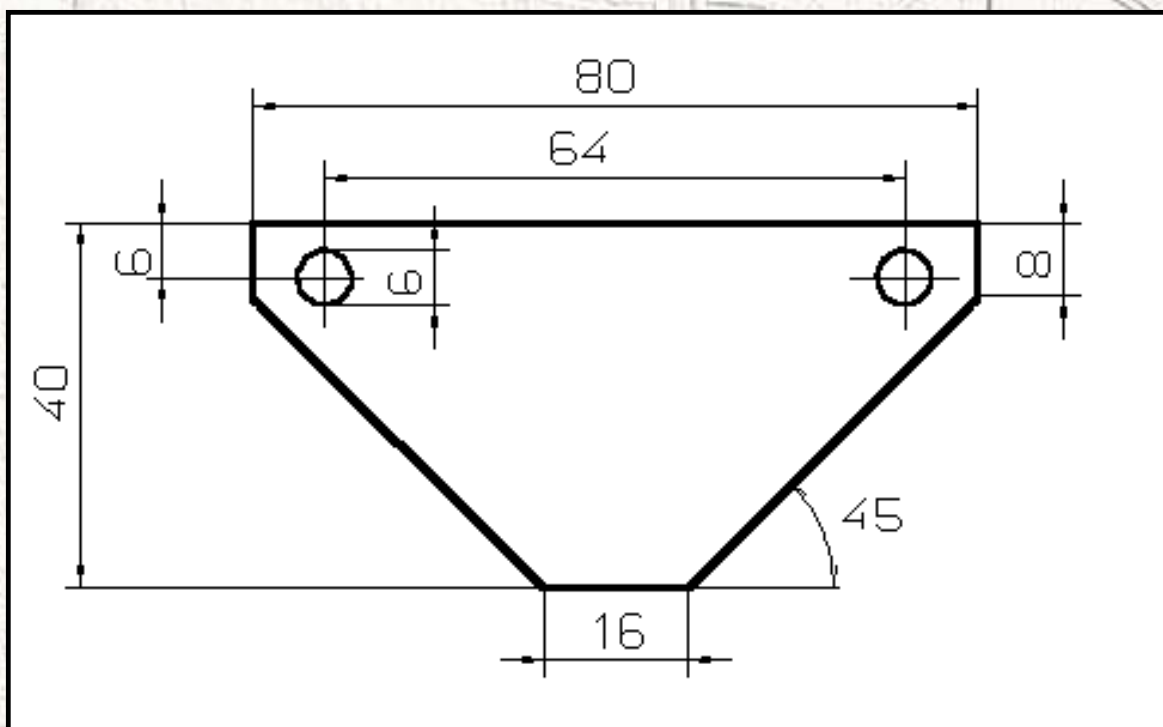
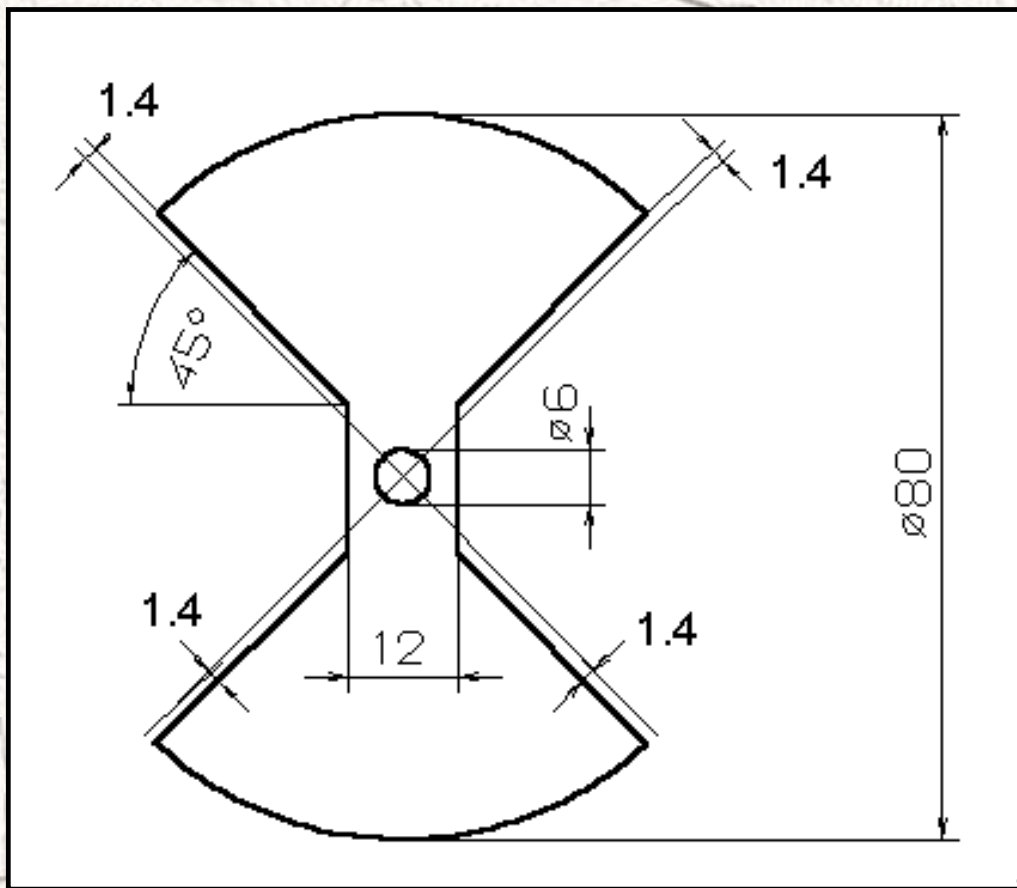

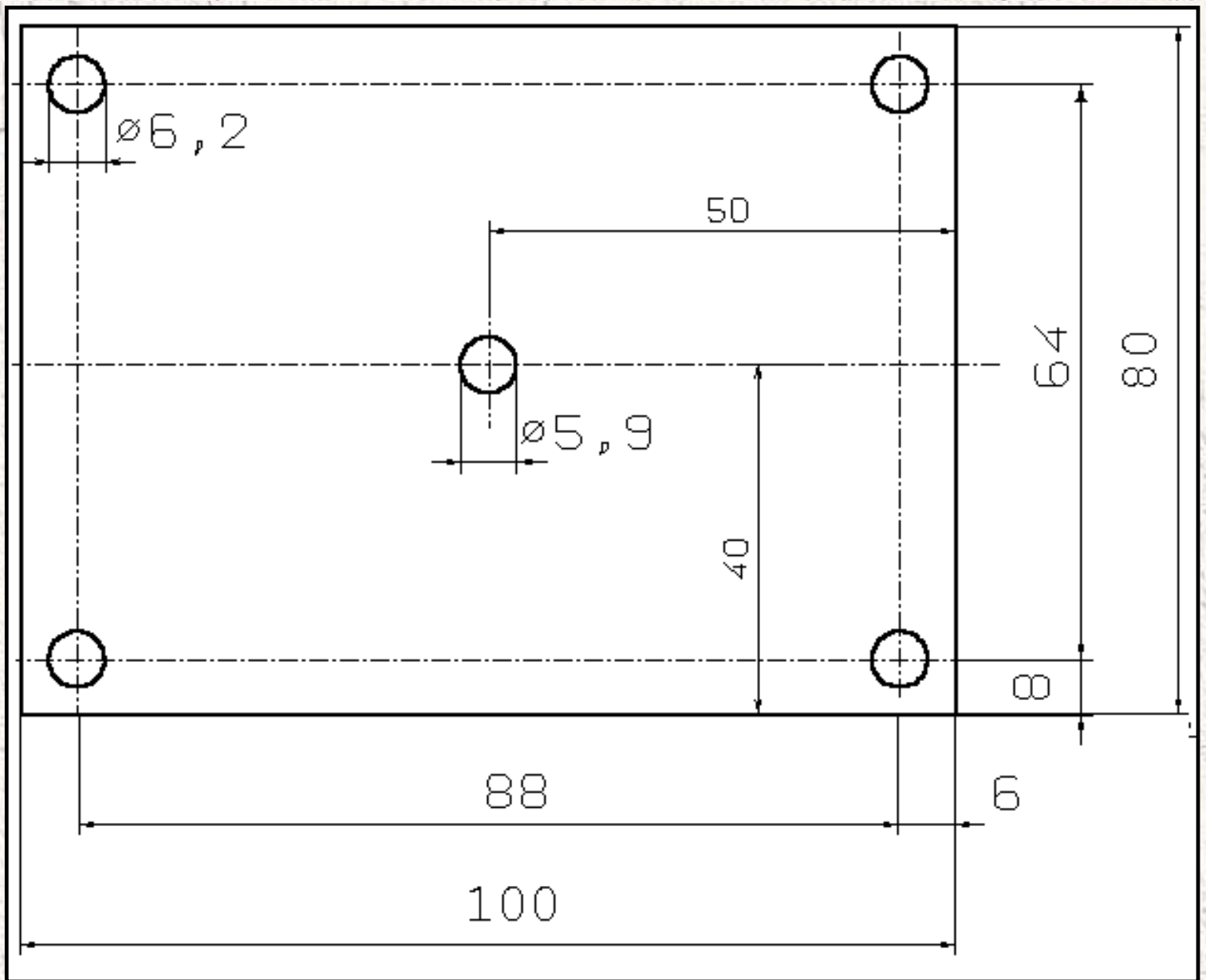

Last Update 03 December 1999. ON4CEQ Van Herck, Tony QTH: Anwerp
(JO21FF) BELGIUM.